



Safehub SEB-2001 Installation Guide

The Safehub SEB-2001 sensor provides clients with real-time, building-specific earthquake damage information to expedite emergency response and recovery. Using easy-to-install sensor devices combined with advanced data analytics, Safehub calculates damage estimates for individual buildings and portfolios in near real time after an earthquake. Through the cloud-based Safehub Platform, users have immediate access to actionable data, via text/email alerts and a web dashboard, that enable them to prioritize building assessments, focus resources, and resume operations as quickly as possible.

This installation guide provides information on how to install a Safehub sensor into a building. Prior to installation, clients should discuss with Safehub, or the client's engineer, the appropriate number of devices to be installed in a building and the optimal device locations.

This guide outlines the steps required to install a single Safehub device.

Table of Contents

- I. An Overview of the Sensor
- II. Choosing the Location
- III. Sensor Installation and Pairing
- IV. Resetting your Sensor
- V. Troubleshooting
- VI. Standards Compliance
- VII. Safehub Limited Hardware Warranty

I. AN OVERVIEW OF THE SENSOR

Before proceeding with installation, familiarize yourself with the components of the Safehub sensor technology:

- Earthquake sensor
- Mounting plate
- Power supply cord

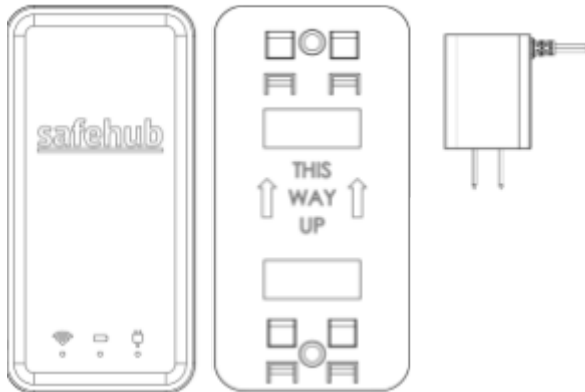

There are three lights on the front of the sensor:

- Left: Cellular Connectivity - indicates that the sensor is connected to a cellular network
- Middle: Internal Battery Power - indicates internal battery strength
- Right: Power outlet light - indicates that the sensor is receiving power from an outlet

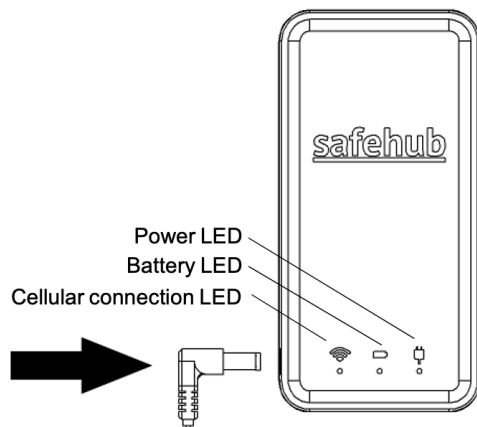

Please note that the Safehub system is cellular-based, so the sensor does not connect to any of your internal networks.

II. CHOOSING THE LOCATION

Please follow these general guidelines when choosing the location of the sensor. Check with your Safehub representative if you need to deviate from these guidelines.

- When installing only one sensor in the building, it should be installed on the ground floor level.
- When installing multiple sensors in the building, consult with your Safehub representative for guidance.
- The sensor should be installed on a solid wall or column, within 12 inches or 30 cm above the floor.
- To reduce issues with cellular-connection, install the sensor on a perimeter wall or a wall close to the perimeter of the building, avoiding locations near the middle of the building.
- Choose a location that is near a power outlet, ensuring the outlet is NOT controlled by a switch to avoid losing power to the sensor.
- Avoid placing the sensor behind large pieces of equipment, such as a printer, or inside cabinets, as this can interfere with cellular service.
- If possible, choose a location near an outlet connected to emergency power.
- Place the sensor in a dry, dust-free location.

For Humid / Dusty Environments:

If the sensor must be installed in a humid or dusty environment, you will need to install Safehub's All-Weather Sensor. Please contact Safehub if you need an All-Weather sensor.

Checking Cellular Signal:

Since the sensors use a cellular connection, check the cellular signal at your chosen location.

Before installing, plug the sensor into the outlet near your chosen location. The right power light will blink for a few seconds, and then all 3 lights will turn on. Wait to see if the left cellular light turns yellow, and then green. The green light ensures adequate cellular connectivity.

If the left cellular light does not turn green within 15 minutes, cellular connectivity may be too weak, and a better location will need to be selected.

If you have any questions about your location selection, reach out to your Safehub representative for further guidance.

III. SENSOR INSTALLATION & PAIRING

Using a drill, find a stud and hold the mounting bracket against the wall at the desired location, locate the screw holes at the top and bottom of the mounting bracket. These holes will be used to drill into the wall

Securely attach the mounting plate to the wall in a vertical position, by screwing the plate into a stud, or by using concrete or masonry anchors as appropriate for the specific type of wall. If the sensor cannot be securely attached to the wall, you'll need to find another location.

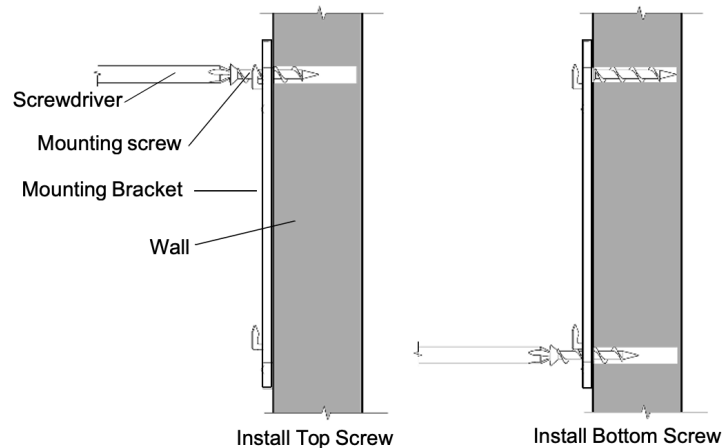

Pairing the Sensor:

Once the mounting plate is secured, pair the sensor with the Safehub platform.

Use your smartphone to scan the QR code on the back of the Safehub sensor. It will bring up a form with a few brief questions.



Alternatively, pair the sensor manually from a web-browser using the link found on the website at: www.safehub.io/installation.

Once you complete the on-line form, securely connect the Safehub sensor into the mounting bracket by sliding it into place.

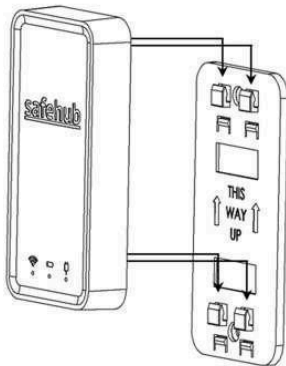

If you've not already done so, plug-in the power supply into the sensor, and then to the power outlet.

It is recommended to use the tie that was provided with the power outlet cord (or tape) to collect any loose cord, reducing the possibility that someone accidentally pulls it out.

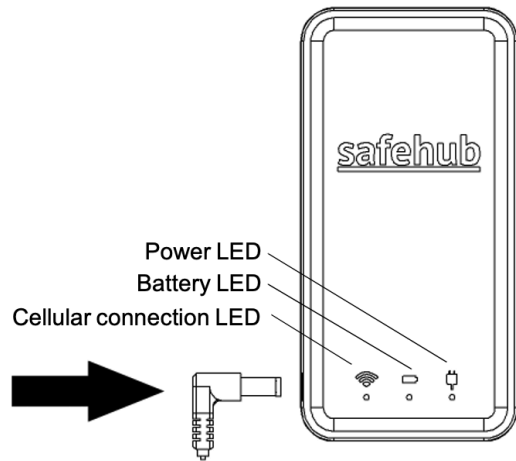

Verifying Sensor Operation:

Once installation is complete, verify the sensor is working properly by checking the light statuses:

- Left cellular light should be green
- Middle battery light should turn green once the internal battery is fully charged
- Right power light should be a solid white

If you have any questions about installing or pairing the sensor, reach out to Safehub for further guidance.

IV. RESETTING YOUR SENSOR

If encountering an issue with the sensor, or you receive a notification from a Safehub representative that the sensor is offline, it may need to be reset.

Slide the Safehub sensor up to remove it from the mounting bracket, and unplug the power supply from the sensor. After a few seconds, you will hear a warning sound indicating that the sensor has been unplugged.

On the back of the sensor, there is a reset button on the lower right. Press & hold the reset button until all lights on the front of the sensor start to flash or turn off. This may take up to 30 seconds. Once they begin flashing or turn off, plug the power supply back into the sensor, and slide it back onto the mounting bracket.

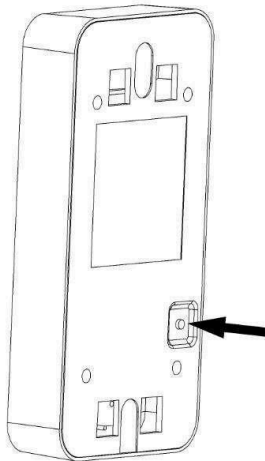

The lights should turn back on, and the sensor is now reset.

Verify the sensor is working properly by checking the light statuses:

- Left cellular light should be green
- Middle battery light should turn green once the internal battery is fully charged
- Right power light should be a solid white

V. TROUBLESHOOTING

If you are seeing disparities in the light statuses, here are some troubleshooting tips to help:

CELLULAR CONNECTION LIGHT IS RED:

If your installation was successful and the cellular connection light was initially green, but is now showing red, that could mean that it is not connected to the cellular network.

Try this: Be sure that the battery light is green indicating that it's fully charged, then slide the sensor off of the mounting bracket, and remove the power supply. Walk with the sensor to another location of the building and wait up to 15 minutes to see if the cellular light turns green there.

If the light turns green in a new location, you may need to relocate and reinstall the sensor to a location with a better cellular connection.

POWER LIGHT IS OFF:

If the right power light is off, the sensor may not be receiving power from the outlet. In this case, the sensor will run off of battery power until the charge runs out (resulting in the middle light to eventually turn yellow, then red).

Try this: If the power light is off, first make sure the power supply is plugged into the sensor and the outlet. If so, next check to see if the outlet itself is receiving power. Sometimes an outlet is controlled by a switch, and turning the switch off could result in power loss for the sensor.

If you find that is the case, you will need to plug the sensor into a different outlet, possibly relocating it.

If you have any questions or encounter other issues with the sensor, reach out to your Safehub representative for further guidance.

VI. STANDARDS COMPLIANCE

This product complies with the following standards:

United States



Federal Communications Commission (FCC) Class A. This device complies with Part 15 of the FCC Rules and with Industry Canada license-exempt RSS standard(s). Operation is subject to the following two conditions: 1) This device may not cause harmful interference 2) This device must accept any interference received, including interference that may cause undesired operation.

Le présent appareil est conforme aux CNR d'Industrie Canada applicables aux appareils radio exempts de licence. L'exploitation est autorisée aux deux conditions suivantes: 1) l'appareil ne doit pas produire de brouillage, et 2) l'appareil doit accepter tout brouillage radioélectrique subi, même si le brouillage est susceptible d'en compromettre le fonctionnement.

This equipment has been tested and found to comply with the limits for a Class B digital device, pursuant to Part 15 of the FCC Rules. These limits are designed to provide reasonable protection against harmful interference in a residential installation. This equipment generates, uses, and can radiate radio frequency energy, and if not installed and used in accordance with the instructions, may cause harmful interference to radio communications. However, there is no guarantee that interference will not occur in a particular installation. If this equipment does cause harmful interference to radio or television reception, which can be determined by turning the equipment off and on, the user is encouraged to try to correct the interference by one of the following measures: 1) Relocate the Safehub device 2) Consult the dealer for help.

This equipment complies with FCC radiation exposure limits set forth for an uncontrolled environment. The end user must follow the specific operating instructions for satisfying RF exposure compliance. This transmitter must not be co-located or operating in conjunction with any other antenna or transmitter. The device is designed to meet the requirements for exposure to radio waves established by the Federal Communications Commission (USA). These requirements set a SAR limit of 1.6 W/kg averaged over one gram of body tissue.

Changes or modifications made to this equipment not expressly approved by Safehub Inc. may void the FCC authorization to operate this equipment.

International



International Electrotechnical Commission (IEC)

This product is designed and tested to comply with the International Electrotechnical Commission (IEC) 60950-1 standard for the safety of Information Technology Equipment. The application of this standard is intended to reduce the risk of injury or damage due to the following hazards: electric shock, energy-related, fire, mechanical and radiation.

The Safehub device is designed to minimize these hazards when it is installed and used according to the instructions in this document and according to commonly observed safety procedures. Follow all warnings in this document while unpacking, installing, operating, servicing, uninstalling, or repacking this device.

This is an Information Technology Equipment (ITE) device, suitable for use in commercial offices, computer rooms, and related commercial facilities. It may not be suitable for other types of facilities including but not limited to selected types of residential, industrial, and medical environments. If there is any doubt about the suitability of the device's use in a particular location, contact Safehub.

EU Regulatory Conformance



Hereby, Safehub declares that the radio equipment type SEB-2001 is in compliance with Directive 2014/53/EU.

The full text of the EU declaration of conformity is available at the following internet address:
<http://aws3.link/TIWEMO>

LTE Radio – LTE-Cat. M1

Bands – B1/B2/B3/B4/B5/B8/B12/B13/B18/B19/B20/B25/B26/B27/B28/B66/B85

Fallback – GSM/EDGE

GSM Bands – 850/900/1800/1900 MHz

Power Class – 5

Max. Output Power – +20.4dBm

Sub-GHz Radio – Disabled until further notice

Costa Rica



Mexico



IFT #: JOSASE24-10821

La operación de este equipo está sujeta a las siguientes dos condiciones:

- (1) es posible que este equipo o dispositivo no cause interferencia perjudicial y
- (2) este equipo o dispositivo debe aceptar cualquier interferencia, incluyendo la que pueda causar su operación no deseada.

Japan



R 003-200139
T D200116003

VII. SAFEHUB LIMITED HARDWARE WARRANTY

THIS LIMITED WARRANTY CONTAINS IMPORTANT INFORMATION ABOUT YOUR RIGHTS AND OBLIGATIONS, AS WELL AS LIMITATIONS AND EXCLUSIONS THAT APPLY TO YOU.

Safehub Inc. ("Safehub," "we," "our" or "us") warrants that its sensor hardware and incorporated software (the "Products") will be free from defects in materials and workmanship, as set forth in this document and in accordance with Safehub's published user documentation, for three (3) years from the date of delivery (this "Limited Warranty").

This Limited Warranty is only valid and enforceable in locations Products are made available by Safehub and its authorized resellers and will apply only if you purchased Products from Safehub or an authorized reseller. This Limited Warranty does not apply if any Safehub serial number or service label has been eliminated or erased. This Limited Warranty does not guarantee that use of Products will be uninterrupted or error free. Further, this Limited Warranty does not apply to damage or defects arising from normal wear and tear; causes not attributable to defects of manufacture and/or defects of material; servicing other than by persons authorized by Safehub; disassembly; lack of maintenance or service of the Product in accordance with applicable documentation; accidents or negligence in use of the Product; abuse or improper use of the Product; presence of sand, spills from liquid substances, water, burns or any foreign element inside the Product; spikes or drops in voltage in the network or connection of the Product to networks whose voltage does not correspond to that listed in the installation guide; or damage caused by any force majeure event or act of God, and, in general, any event that is outside the reasonable control of Safehub, including, but not limited to damage caused by floods, earthquakes, fires, thunderstorms, electrical storms, shock, or improper transportation.

To make a claim under this Limited Warranty, please contact our customer service department at support@safehub.io and provide your name, contact information and the serial number and service label on your Product. You are required to send the Product to Safehub, to the facility or address provided by Safehub, and Safehub will test the Product and validate the claim. In the case of a validated claim, Safehub will, in its sole discretion and to the extent permitted by law, either repair your Product using new or refurbished parts or replace your Product with a new or refurbished Product at least as functionally equivalent to yours. If Safehub repairs or replaces Products, the repaired or replaced Products will continue to be warranted under this Limited Warranty solely for the remaining time of the original warranty period.

THIS LIMITED WARRANTY IS THE ONLY EXPRESS WARRANTY SAFEHUB PROVIDES FOR THE PRODUCTS AND, TO THE MAXIMUM EXTENT PERMITTED BY APPLICABLE LAW, THE REMEDY SET FORTH HEREIN IS YOUR SOLE REMEDY. TO THE MAXIMUM EXTENT PERMITTED BY APPLICABLE LAW, SAFEHUB EXPRESSLY DISCLAIMS ALL OTHER WARRANTIES AND CONDITIONS OF ANY KIND, WHETHER STATUTORY OR IMPLIED, ARISING FROM COURSE OF CONDUCT OR OTHERWISE, REGARDING THE PRODUCTS. TO THE MAXIMUM EXTENT PERMITTED BY APPLICABLE LAW, IN NO EVENT SHALL SAFEHUB, ITS AFFILIATES, AGENTS, DIRECTORS, EMPLOYEES, SUPPLIERS OR LICENSORS BE LIABLE FOR ANY DIRECT, INDIRECT, PUNITIVE, INCIDENTAL, SPECIAL, CONSEQUENTIAL OR EXEMPLARY DAMAGES, INCLUDING WITHOUT LIMITATION DAMAGES FOR LOSS OF PROFITS, GOODWILL, USE, DATA OR OTHER LOSSES, THAT RESULT FROM A BREACH OF THIS LIMITED WARRANTY OR THE USE OF, OR INABILITY TO USE, THE PRODUCTS.

NO SAFEHUB EMPLOYEE OR REPRESENTATIVE OR ITS AFFILIATES OR ANY THIRD PARTY IS AUTHORIZED TO MAKE ANY MODIFICATION, EXTENSION OR ADDITION TO THIS LIMITED WARRANTY OR ANY PART OF THIS AGREEMENT. IF ANY TERM OF THIS LIMITED WARRANTY IS HELD TO BE ILLEGAL OR UNENFORCEABLE, THE REMAINING TERMS OF THIS LIMITED WARRANTY WILL REMAIN IN FULL FORCE AND EFFECT.

SOME STATES, PROVINCES OR JURISDICTIONS DO NOT ALLOW THE EXCLUSION OR LIMITATION OF CERTAIN IMPLIED WARRANTIES OR INCIDENTAL OR CONSEQUENTIAL DAMAGES, SO THE ABOVE LIMITATIONS OR EXCLUSIONS MAY NOT APPLY TO YOU. THIS AGREEMENT GIVES YOU SPECIFIC LEGAL RIGHTS, AND YOU MAY ALSO HAVE OTHER RIGHTS WHICH VARY FROM JURISDICTION TO JURISDICTION. THE DISCLAIMERS, EXCLUSIONS, AND LIMITATIONS OF LIABILITY UNDER THIS AGREEMENT WILL NOT APPLY TO THE EXTENT PROHIBITED BY APPLICABLE LAW.

Contact Information:

Address: 45 South Park St., San Francisco, CA 94107 Web: www.safehub.io

